

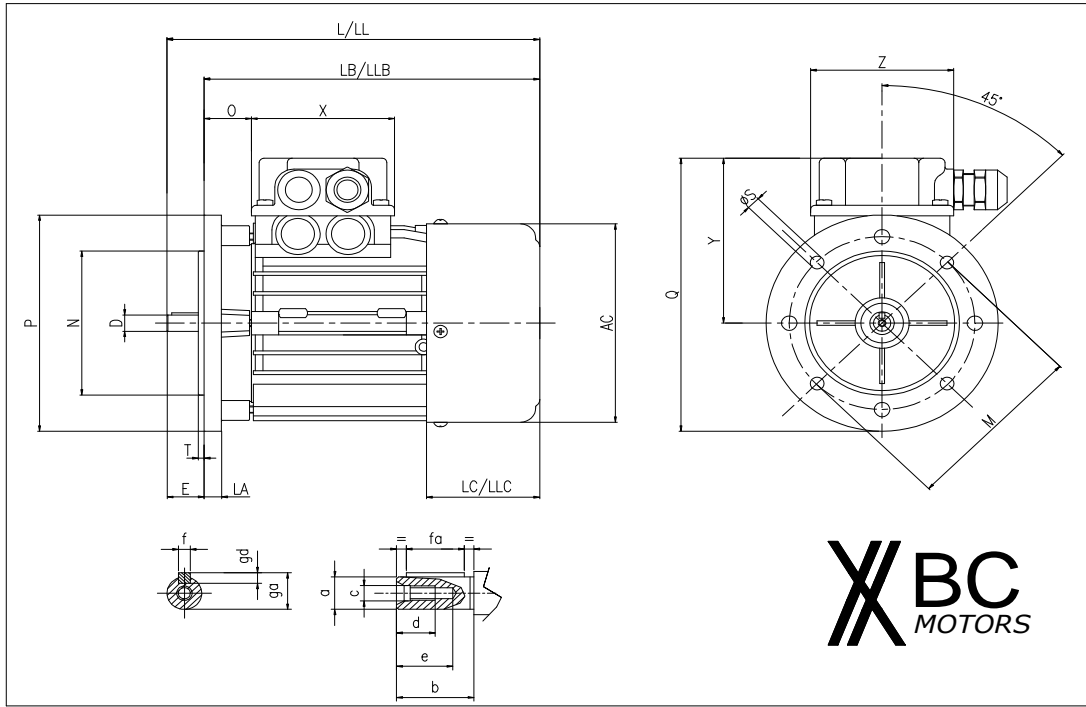

CONSTRUCTIVE DIMENSIONS / B5T THREE-PHASE ASYNCHRONOUS MOTORS FORMA CONSTRUCTIVA / B5T MOTOR TRIFASICO



IEC	a	b	c	d	e	fa	f	gd	ga
56	9	20	M4	10	14	15	3	3	10,2
63	11	23	M4	10	14	15	4	4	12,5
71	14	30	M5	12,5	17	25	5	5	16
80	19	40	M6	16,5	21	30	6	6	21,5
90	24	50	M8	19	25	35	8	7	27
100/112	28	60	M10	22	30	50	8	7	31
132	38	80	M12	32	44	60	10	8	41
160	42	110	M16	30	44	90	12	8	45

MOTORES CON FRENO

IEC	N	M	P	D	E	O	S	Q	L	LB	LC	X	Z	T	LA	Y	AC	LL	LLB	LLC
56	80	100	120	9	20	24,5	7	152	193	173	58,5	74	74	3	9	91,5	110	235	215	100
63	95	115	140	11	23	27	9	168	212	189	62,5	74	74	3	10,5	98	123	260	237	110
71	110	130	160	14	30	35	9	186	246	216	76	74	74	3,5	10	105	136	300	270	130
80	130	165	200	19	40	34,6	12	222	275	235	81	89	89	3,5	11	122	156	334	294	140
90S	130	165	200	24	50	38,6	12	227	301	251	90	89	89	3,5	10,5	127	176	361	311	150
90L	130	165	200	24	50	38,6	12	227	326	276	90	89	89	3,5	10,5	127	176	386	336	150
100	180	215	250	28	60	44,5	14	263	364	304	97	89	89	4	15,5	138	194	437	377	170
112	180	215	250	28	60	47,6	14	275	388	328	104	89	89	4	15,5	150	218	474	414	190
132S	230	265	300	38	80	54,5	14	327	450	370	120	104	104	4	20	177	257	550	470	220
132M	230	265	300	38	80	54,5	14	327	488	408	120	104	104	4	20	177	257	588	508	220
160M	250	300	350	42	110	56	18	415	602	492	135	186	186	5	14	240	310	717	607	250
160L	250	300	350	42	110	56	18	415	646	536	135	186	186	5	14	240	310	761	651	250

IEC	a	b	f	ga	N	M	P	D	E	S	L	T	LA
180M	48	105	14	51,5	250	300	350	48	110	18,5	625	5	15
180L	48	105	14	51,5	250	300	350	48	110	18,5	625	5	15
200L	55	105	16	59	300	350	400	55	110	18,5	790	5	15
225S	60	135	18	64	350	400	450	60	140	18,5	820	5	15
225M	55	105	16	59	350	400	450	55	110	18,5	790	5	15
225M	60	135	18	64	350	400	450	60	140	18,5	820	5	15
250M	60	135	18	64	450	500	550	60	140	18,5	900	5	18
250M	65	135	18	69	450	500	550	65	140	18,5	900	5	18
280S	65	135	18	69	450	500	550	65	140	18,5	930	5	18
280S	75	135	20	79,5	450	500	550	75	140	18,5	930	5	18
280M	65	135	18	69	450	500	550	65	140	18,5	980	5	18
280M	75	135	20	79,5	450	500	550	75	140	18,5	980	5	18
315S	65	134	18	69	550	600	660	65	140	24	983	6	22
315S	80	174	22	85	550	600	660	80	170	24	1013	6	22
315S/M	65	134	18	69	550	600	600	65	140	24	1038	6	22
315S/M	80	174	22	85	550	600	600	80	170	24	1068	6	22
315M/L	65	134	18	69	550	600	660	65	140	24	1280	6	22
315M/L	80	174	22	85	550	600	660	80	170	24	1320	6	22